



Simply.
More.
Safety.

Assembly Instructions

AMFE Mounting Kit Cabinet Top



Table of Content

1.	General Safety Instructions	3
2.	Description	4
3.	What is in the package	4
4.	Tools	5
5.	Assembly Instructions	5
6.	Disclaimer	7





JOB part number	AMFE mounting holder set for all cylinder variants incl. brackets
100870	AMFE mounting holder set size 0
100871	AMFE mounting holder set size 1
100894	AMFE mounting holder set size 2
100893	AMFE mounting holder set 3 & 4
100892	AMFE mounting holder set size 5

1. General Safety Instructions

The AMFE is an industrial product, which must be handled with care and following the instructions as lined out in this manual.



BEFORE handling products of the AMFE line, these instructions and safety guidelines have to be read and understood by all people handling and/or working with these products.

Assembly, installation, service and maintenance shall only be carried out by technically knowledgeable personnel.

	Always handle the AMFE and cylinders with care!
	Do not drop it!
	Wear safety glasses when handling and/or installing the AMFE!

This instruction contains no information about general or special knowledge of fire extinguishing systems.

In addition to following the instructions of this manual, all locally applicable safety regulations have to be obeyed. The manufacturer cannot be held responsible for damages resulting from failure to use the AMFE products as intended.

	
Never try to unscrew the cylinder adapter with the rupture disc sealing from the pressurized red extinguishing agent cylinder!	

2. Description

The Mounting Kit for Cabinet tops allows easy installation of the AMFE product line when only limited space is available inside an enclosure that needs to be protected. The cylinders containing the extinguishing agent are herewith placed outside the actual protected volume / enclosure, whilst the initiation head of the AMFE product series (AMFE, S-AMFE or R-AMFE) is placed inside. The activation head is able to react thermally on temperatures from an emerging fire at the earliest possible time, opening the attached extinguishing agent cylinder to distribute the extinguishing agent.

Picture: application example



3. What is in the package

See package:

- 1 x mounting holder
- 1 x double membrane socket
- 2 x lag bolt M10x12
- 2 x compatible nuts
- 1 x bracket set
(Carton including one or two brackets depending on set size)



4. Tools

- Electric drill
- Suitable drill, depending on the size (6,6mm or 10,5mm) as well as a 32mm drill
- Sandpaper or file
- Measuring tape or similar
- 2 x wrenches metric M10
- 1 x wrench Metric M15
- 1 x wrench metric M17
- 1 x wrench metric M19
- 1 x wrench Metric M24
- Cutter knife

5. Assembly Instructions

- 1.) Prepare the **AMFE Mounting Kit parts including AMFE bracket set** and the **AMFE head with matching cylinder**.



- 2.) Use the different drilling templates for the right size to find measurements and positions. Drill three holes as shown in the picture.

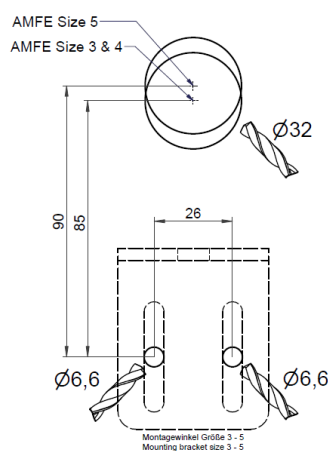
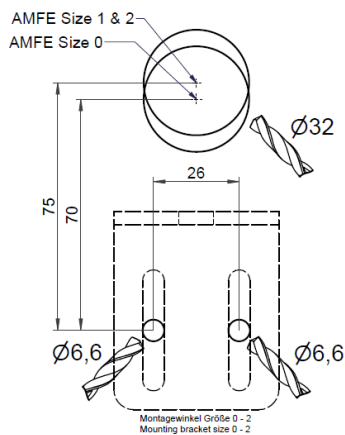

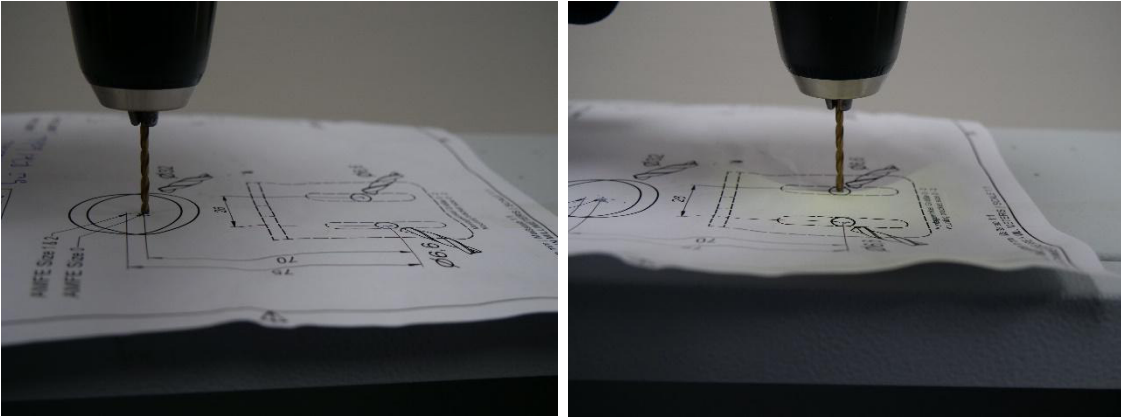

For the big hole different drills are possible (see exemplary below pictures)

3.) Cut double membrane socket in the middle and place it in the hole.

4.) Position the holder and use bolt and nuts to mount the holder to the cabinet.



In the bracket sets two washers are provided.
For the installation of the mounting holder set **only one washer is needed.**

5.) There are two options to install the AMFE activation head

Option a.)

Place the double diaphragm nozzle in the 32 mm hole, insert the cartridge, fix the AMFE with the bracket(s) to the holder and then assemble (glue) the AMFE activation unit.

It is not possible to lock the valve of the cartridge during mounting

CAUTION DURING DISASSEMBLY!

Option b.)

Place the double diaphragm nozzle on the valve of the cylinder, mount the trigger unit on the cartridge (glue it), then carefully thread the trigger unit through the opening and then mount the cartridge.

6. Disclaimer

This product is manufactured by

JOB GmbH
Kurt-Fischer-Str. 30
D-22926 Ahrensburg / Germany
Tel: +49 (0) 4102 2114-0

Email: info@job-group.com
Web: www.job-group.com

The product is **“MADE IN GERMANY”** and manufactured in accordance with all applicable standards and laws for the place of manufacturing.

Part No.	Artikel / Part
100870	AMFE WINKEL / Mounting Bracket SET 0
100871	AMFE WINKEL / Mounting Bracket SET 1
100894	AMFE WINKEL / Mounting Bracket SET 2
100893	AMFE WINKEL / Mounting Bracket SET 3/4
100892	AMFE WINKEL / Mounting Bracket SET 5

Bohrschablone / drill template

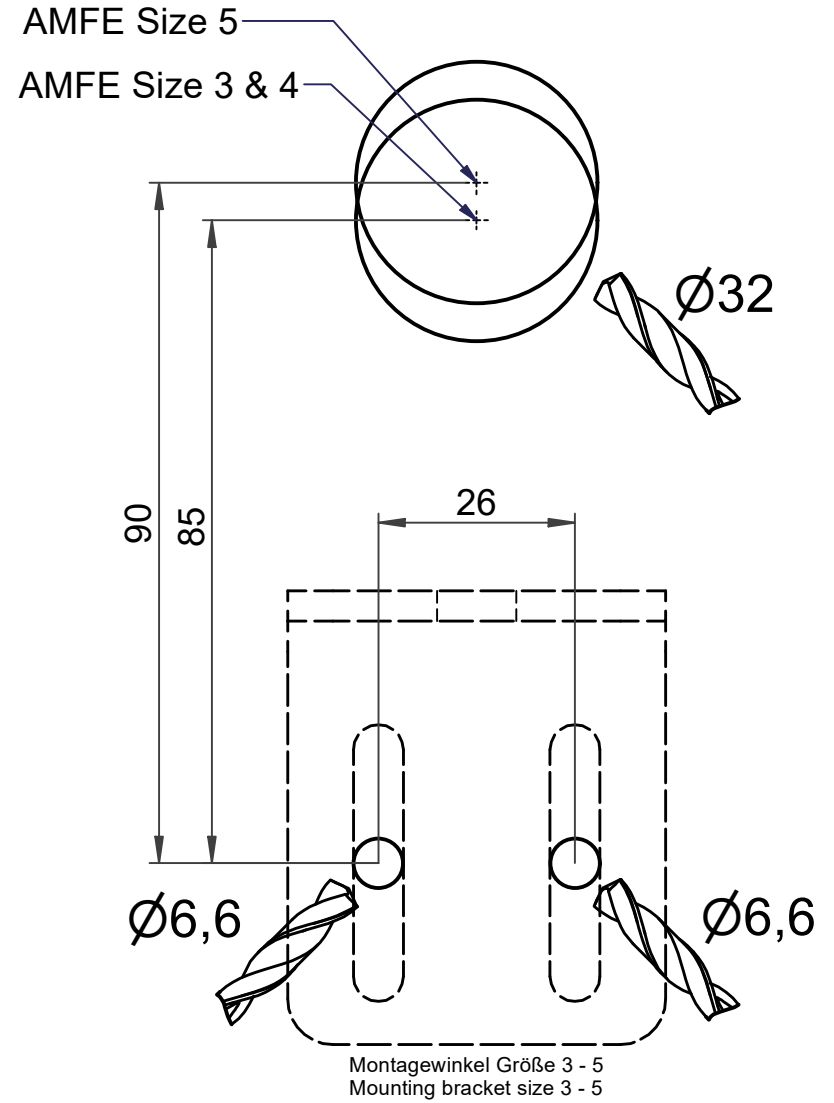
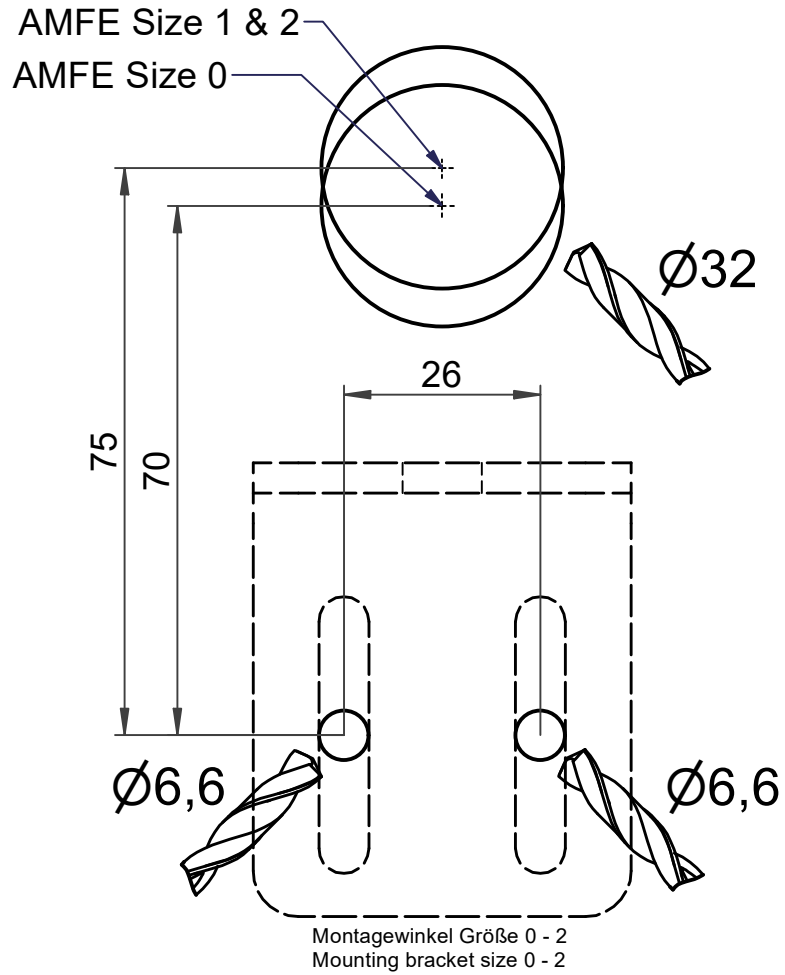

Alle Maßangaben in mm | Maßstab 1:1
All DIMENSIONS ARE IN MILLIMETERS | SCALE 1:1

Bohrschablone f. 40-069-24-103 u. 40-069-24-101 | 25.07.2024